

Series TLE

THERMOSTATIC EXPANSION VALVES FIXED ORIFICE, ADJUSTABLE SUPERHEAT SETTING

PRODUCT DATA



Features

- **TLE:** with internal pressure equalisation; for single injection in installations with one or more cooling circuits.
- **TLEX:** with external pressure equalisation; for optimal evaporation effectiveness in all applications. Obligatory for multiple injection by liquid distributors.
- **Combi adsorber charge as standard.** The same valve can be used for different refrigerants (see table on page 2)
 - Controller charge is high sensitive and responsive thus lowest possible level of superheat can be achieved
 - Charge is not sensitive to effects of temperature on the capillary tube and valve head
 - damping characteristic results in stable control behaviour
- Gas charge for deep freeze applications
- Adjustable superheat setting
- Warm thermal head provides best reliability
- Solder connections
- Extreme durable due to stainless steel head and stainless steel diaphragm welded using protective gas
- Fixed orifice
- Refrigerants: R134a, R401A, R12
R22, R407C, R407A
R404A, R507, R402A, R407B, R502
R410A
R23, ISC 89, R508A, R508B
Further refrigerants on request.

Application

Thermostatic expansion valves series TLE and TLEX are used in plants with one or more refrigerant circuits, in particular for series systems such as heat pumps, refrigerated cabinets, deep freeze chests, freezers, fermentation interrupters, ice and cream machines, compact systems in refrigeration and air conditioning.

Materials

Body	brass
Thermal head	stainless steel
Connection tubes	copper

Specification

Nominal capacity range	1 to 16 kW R22 (small orifice graduation for optimal control behaviour)
Evaporating temperature range	see table on page 2
Maximum pressure PS	29 bar
Maximum test pressure	32 bar
Max. ambient temperature	100 °C
Max. bulb temperature	140 °C
Static superheat	approx. 3 K
Length of capillary tube	1.5 m
Bulb diameter	12 mm

Thermal Charges and Temperature Ranges

1. Adsorber charge

Refrigerant	Evaporation temperature range
R134a, R401A, R12	+15 °C to -30 °C
R22, R407C, R407A	+15 °C to -45 °C
R404A, R507, R402A, R407B, R502	±0 °C to -50 °C

Further refrigerants on request.

Thermal systems with adsorber charge are completely insensitive to effects of temperature on the capillary tube and valve head. It reacts only according to the temperature of the bulb.

Thus, Honeywell TLE valves with combi adsorber charge work absolutely reliable, even in icy condition or while defrosting using hot gas.

2. Adsorber charge with pressure limiting performance (MOP)

Refrigerant	Evaporation temperature range	MOP
R134a, R401A,	+5 °C to -30 °C	MOP A +15 °C
R12	-10 °C to -30 °C	MOP A ±0 °C
R22, R407C, R407A	+5 °C to -45 °C	MOP A +15 °C
	-10 °C to -45 °C	MOP A ±0 °C
	-27 °C to -45 °C	MOP A -18 °C
R404A, R507, R402A, R407B,	-10 °C to -50 °C	MOP A ±0 °C
	-20 °C to -50 °C	MOP A -10 °C
R502	-27 °C to -50 °C	MOP A -18 °C

Further refrigerants and MOP on request.

3. Gas charge

Refrigerant	Evaporation temperature range	MOP
ISC 89	-40 °C to -70 °C	MOP -40 °C
	-55 °C to -70 °C	MOP -55 °C
R23	-40 °C to -80 °C	MOP -40 °C
	-55 °C to -80 °C	MOP -55 °C
R410A	-40 °C to -70 °C	MOP -40 °C
	-55 °C to -70 °C	MOP -55 °C
R508A	-40 °C to -90 °C	MOP -40 °C
	-55 °C to -90 °C	MOP -55 °C
R508B	-40 °C to -100 °C	MOP -40 °C
	-55 °C to -100 °C	MOP -55 °C

Further refrigerants and MOP on request.

With gas charged valves and MOP it is under all operating conditions necessary that the bulb is always colder than the capillary tube and the thermal head!

With the Honeywell TLE series the thermal head is heated advantageously by the liquid refrigerant. The warm thermal head is on the safe side at any time.

Capacities

Type	Orifice size	Nominal capacity (kW*)		
		R134a	R22 R407C	R404A R507
TLE and TLEX	0.5	0.65	1.0	0.7
	0.7	0.9	1.3	1.0
	1.0	1.3	1.9	1.5
	1.5	2.1	3.1	2.3
	2.0	2.7	3.9	2.9
	2.5	3.8	5.6	4.2
	3.0	6.2	8.9	6.7
	3.5	8.2	11.7	8.8
	4.5	11.1	16.3	12.3

* Capacities are based on $t_0 = -10\text{ °C}$, $t_c = +25\text{ °C}$ and 1 K subcooled liquid refrigerant entering the valve.

For other operating conditions see capacity charts in Honeywell catalogue or consult the Honeywell software.

Dimensions and Weights

Type	Orifice size	Connections			Weight (kg)	
		Inlet (A)	Outlet (B)	Pressure equaliser (C)		
TLE and TLEX	0.5	6 mm ODF	12 mm ODF	6 mm ODF	approx. 0.32	
	0.7	1/4" ODF	1/2" ODF	1/4" ODF		
	1.0					
	1.5	10 mm ODF	12 mm ODF	6 mm ODF		
	2.0					
	2.5					
	3.0	3/8" ODF	1/2" ODF	1/4" ODF		
	3.5					
	4.5	4.5	10 mm ODF	16 mm ODF		6 mm ODF
			3/8" ODF	5/8" ODF		1/4" ODF
12 mm ODF			16 mm ODF	6 mm ODF		
1/2" ODF			5/8" ODF	1/4" ODF		

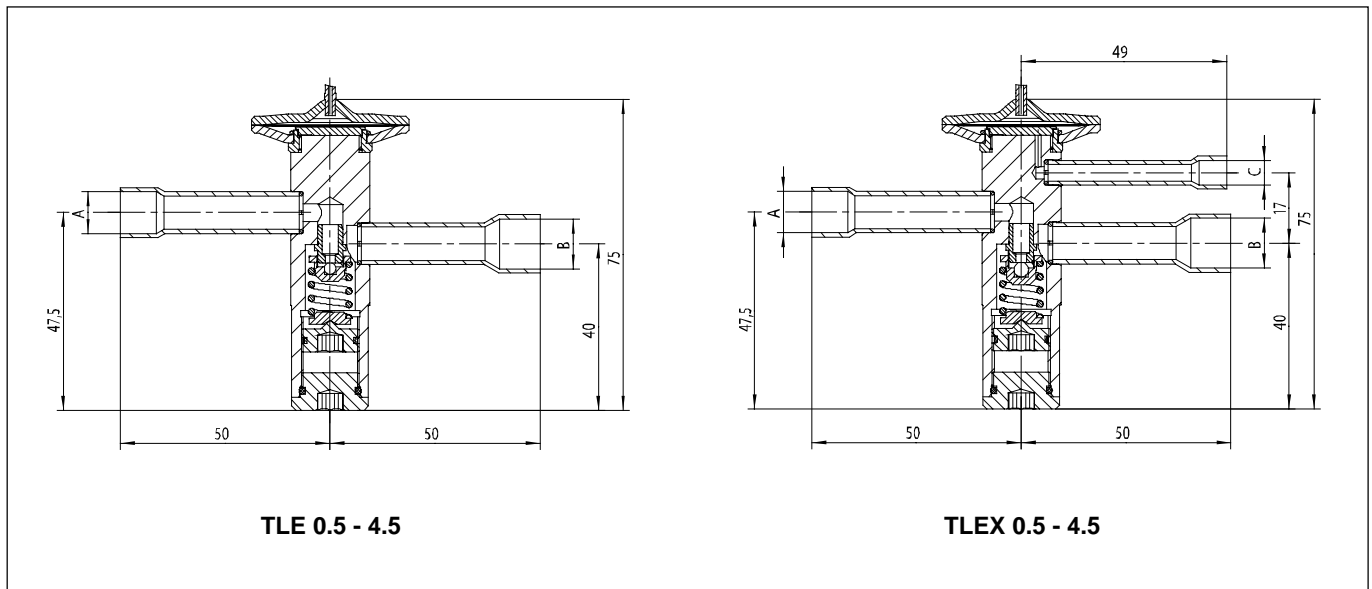

Type Code / Order Information

	TLE	X	0.7	R22	MOP A -18 °C	3/8" x 1/2"
Series						
Pressure equalisation: X = external () = internal						
Orifice size						
Refrigerant						
Adsorber charge with MOP () = Adsorber charge without MOP						
Solder connection ODF (inlet x outlet)						

Installation

- The valves may be installed in any position.
- The external pressure equaliser line (TLEX) should be 6 mm or 1/4" in diameter and is to be connected downstream of the remote bulb. An overbow is recommended in order to prevent the ingress of oil into the equaliser line.
- The bulb should preferably be positioned on the upper half of a horizontal suction line but never after a liquid trap. As a general rule, bulbs of expansion valves should be insulated to prevent them being affected by the ambient temperature.
- When soldering the valve, the valve body must not get warmer than 100 °C.
- Do not bend or squeeze the bulb when tightening the bulb clamp!
- Constructive modifications at the valve are not allowed.

Information for original equipment manufacturers:

The valve series TLE can be customised to the requirements of your series device in an optimum way. Contact us!

Superheat Adjustment

In general the Honeywell valves should be installed with the factory setting for the used refrigerant unaltered.

At combi adsorber valves the label on the capillary tube indicates how to adjust the adjusting spindle (with arrow for direction), depending on the refrigerant used. This correction of the adjustment is essential to ensure that the control performance of the valve is correct. The refrigerant used must be marked on the label.

This superheat adjustment is calibrated for lowest superheating and optimum evaporator utilisation. However, should it be necessary to adjust the superheat, turn the adjusting spindle as follows:

Turning clockwise = reduced refrigerant mass flow, increase of superheat

Turning counterclockwise = increased refrigerant mass flow, decrease of superheat

One turn of adjusting spindle alters superheat setting by approx. 0.25 bar. Increase of superheat setting results in a lower MOP-value and vice versa.

Honeywell

Automation & Control Solutions

Honeywell GmbH
Hardhofweg
74821 Mosbach/Germany
Phone: +49 (0) 62 61 / 81-475
Fax: +49 (0) 62 61 / 81-461
E-Mail: cooling.mosbach@honeywell.com
www.honeywell-cooling.com